

August 27, 2009

Mrs. Tina Butcher
NIST, Weights & Measures Div
100 Bureau Drive, MS 2600
Gaithersburg, MD 20899

Subject: Agenda Item

I used the Canadian Document VO-AP-037, Version 00.02 on Linearization Functions Incorporated in Measuring Instruments as the basis for this item. I did not find any copyright so I hope this is legal. If not, please delete.

I added a paragraph to the Scope. This paragraph would bring electronic output PD meters, turbine meters, etc that do not have a shaft output on equal requirements as other meters that currently incorporate electronics in the measuring device.

1.2 Scope

This procedure applies to pulse processing electronic devices incorporating the linearization of the pulse per unit volume versus pulse frequency. This includes all flow computers, electronic registers, correction devices and supporting software external to the measuring device. The tests verify the proper functioning and accuracy of the linearization schemes.

For pulse processing electronic devices incorporating the linearization of the pulse per unit that is within the measuring device, the results of the device accuracy and endurance tests will verify the complete measuring device capabilities. The linearization electronics of the measuring device must be protected from tampering and fraud utilizing a physical seal. No separate tests on parts of the measuring device are required.

2.1 Equipment Requirements

This needs to be reviewed by the electronic group. When we tested our linearization board in Canada, we had problems because their Dual Channel Pulser off position of the pulse did not go close enough to zero volts. We furnished them a dual channel pulser that goes down to within 0.2 volts in the off part of the pulse and then their counters worked fine.

2.5.1 and 2.5.3

The word "devices" should be "EUT"

2.6.2.1 and 2.6.2.3

Do not limit "meter Factors" to 4 or 5 points. See revised 2.6.2.5 as a method to test all points the device is capable of.

2.6.2.5

Delete Runs #2 through #5 and replace with:

2. Select frequencies that results in flow rates that lie between each pair of points programmed in 2.6.2.3. Test at each frequency.

Change Run number 6 to number 3.

One other area that I would support a change is the limit of 3 to 5 factors. The regulation should be written to cover any number of factors.



Maurice Forkert
Compliance and
Design Engineer



Measurement
Canada

AN ACT TO ESTABLISH

Mesures
Canada

LOI SUR LE SYSTÈME

**Approval and Calibration Services Laboratory
Technical Manual**

APPROVAL PROCEDURE

FOR

**LINEARIZATION FUNCTIONS INCORPORATED IN
MEASURING INSTRUMENTS**

DOCUMENT NUMBER

VO-AP-037

VERSION: 00.02



Measurement
Canada

En Mesures, Canada

Mesures
Canada

En Mesures, Canada

Approval and Calibration Services Laboratory Technical Manual

Document Title: LINEARIZATION FUNCTIONS INCORPORATED IN MEASURING INSTRUMENTS Document number: VO-AP-037	Version No.: 00.02	Page 3 of 19
--	---------------------------	---------------------

RECORD OF CHANGE

Version	Date	Description
00.01	2005.11.30	Original Release
00.02	2005.12.08	Correct errors, make small improvements to document Add section for Step type linearization scheme.

Document Title: LINEARIZATION FUNCTIONS INCORPORATED IN MEASURING INSTRUMENTS	Version No.: 00.02	Page 4 of 19
Document number: VO-AP-037		

TABLE OF CONTENTS

1.0	INTRODUCTION	4
1.1	Purpose	4
1.2	Scope	4
1.3	Applicable Documents	4
1.4	Abbreviations and Symbols	4
2.0	PROCEDURE	4 - 12
2.1	Equipment Requirements	4 - 5
2.2	Software Requirements	5
2.3	Environmental Requirements	5
2.4	Safety Requirements	5
2.5	Set-up	5 - 6
2.6	Instructions	6 - 9
2.7	Calculations	10 - 12
2.8	Pass/Fail Criteria	12
3.0	APPENDICES, WORK SHEETS AND TABLES	13 - 15
3.1	Appendix A General requirements checklist - Linearization function	13 - 14
3.2	Appendix B Linearization function test sheet	15

<p>Document Title: LINEARIZATION FUNCTIONS INCORPORATED IN MEASURING INSTRUMENTS Document number: VO-AP-037</p>	<p>Version No.: 00.02</p>	<p>Page 5 of 19</p>
---	----------------------------------	----------------------------

1.0 INTRODUCTION

1.1 Purpose

This approval procedure (AP) describes the process to evaluate the linearization functions incorporated in electronic measuring devices in order to determine compliance with applicable requirements, as provided in the *Weights and Measures Act and Regulations*.

1.2 Scope

This procedure applies to pulse processing electronic devices incorporating the linearization of the pulse per unit volume factor versus pulse frequency. This includes all flow computers, electronic registers, correction devices and supporting software external to the device. The tests verify the proper functioning and accuracy of the linearization schemes .

SEE ADDED PARAGRAPH

1.3 Applicable Documents

Document Number	Document Title
	<i>Weights and Measures Act and Regulations Sections SVM-1</i>
GN-LP-003	Vocabulary of Technical and Metrological Terms

1.4 Abbreviations and Symbols

N/A	
-----	--

2.0 PROCEDURE

2.1 Equipment Requirements

2.1.1 Standards

Document Title: LINEARIZATION FUNCTIONS INCORPORATED IN MEASURING INSTRUMENTS	Version No.: 00.02	Page 6 of 19
Document number: VO-AP-037		

Standard Number	Description / Performance Requirements
N/A	

2.1.2 Other Equipment

Equipment Description	Performance Requirements
Pulse Generator	The maximum frequency must be greater than the maximum input frequency of the electronic device under test. Variable output voltage of 5V with a frequency output of $\pm 0.1\%$ or better.
Universal Counter	The maximum frequency must be greater than the maximum rated input frequency of the electronic device under test.
Dual Channel Pulser	Dual channel, variable phase shift (0° , 90° , 120° , 180°), variable output voltage (5V, 12V, 24V)

?
←

2.2 Software Requirements

Software Name	Description / Performance Requirements
Microsoft Excel ASL_Linearization.xls	Accepts 4 or 5 values for the meter factor (MF) or the K factor versus flow rates, as provided by the manufacturer. During test runs, the correct factor is calculated by interpolating in between flow rates and used to measure the device's accuracy.

← ?
0

2.3 Environmental Requirements

Temperature	N/A
Humidity	N/A
Pressure	N/A

2.4 Safety Requirements

Kindly refer to the applicable Measurement Canada Health and Safety documentation.

<p>Document Title: LINEARIZATION FUNCTIONS INCORPORATED IN MEASURING INSTRUMENTS Document number: VO-AP-037</p>	<p>Version No.: 00.02</p>	<p>Page 7 of 19</p>
---	----------------------------------	----------------------------

2.5 Set-up

Kindly refer to the block diagram below for details of equipment setup and connections.

Linearization test Set-up

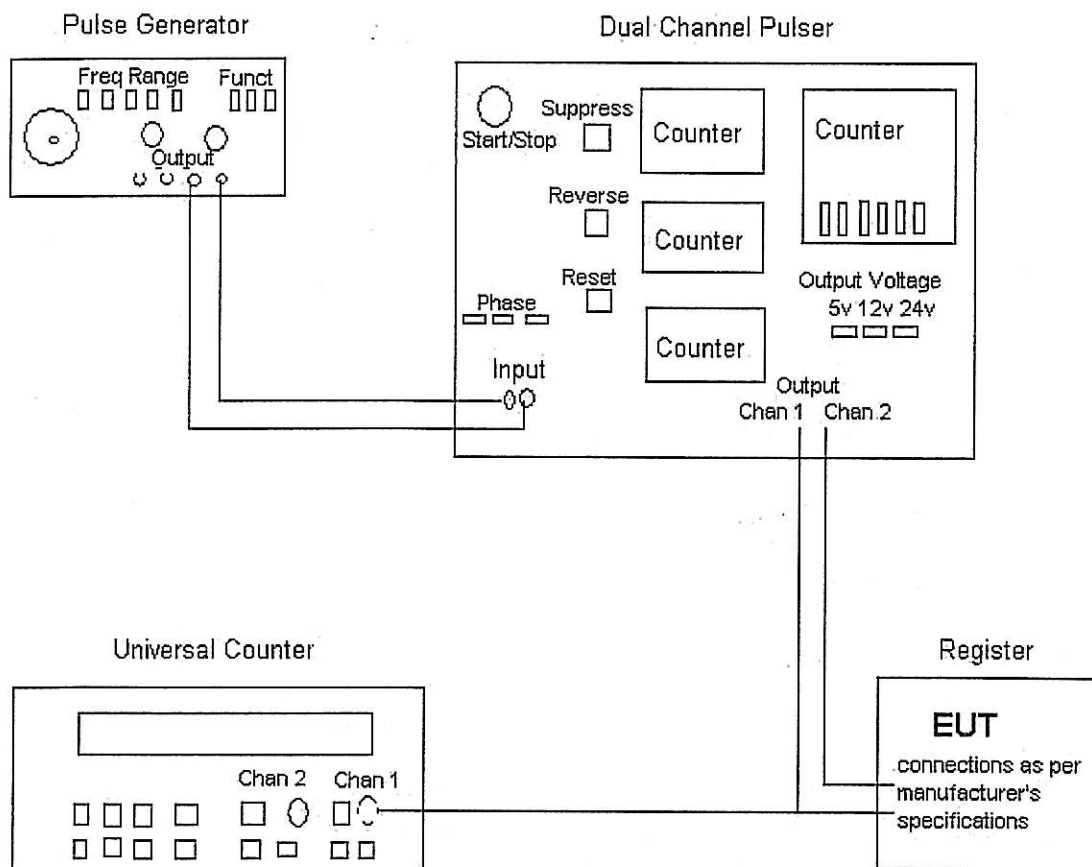

- 2.5.1 Connect the Output of the Pulse Generator to the Input of the Dual Channel Pulser, making sure to connect the positive terminals together and the negative (ground) terminals together. Select a "square wave" function and a frequency in between the maximum and minimum range of the device. ? EUT
- 2.5.2 On the Dual Channel Pulser select the appropriate phase shift (90°, 120° or 180°) and voltage output for the device (5V, 12V or 24V). Connect the Output of Channel 1 of the Pulser to both the Input Channel 1 of the Universal Counter and to the Input of the device, as specified by the manufacturer. EUT
- 2.5.3 Connect the Output of Channel 2 of the Dual Channel Pulser to the Input of the device, as specified by the manufacturer. EUT

Document Title: LINEARIZATION FUNCTIONS INCORPORATED IN MEASURING INSTRUMENTS	Version No.: 00.02	Page 8 of 19
Document number: VO-AP-037		

2.6 Instructions

2.6.1 Familiarize yourself with the device's measurement adjustment scheme. Applying codes supplied by the manufacturer, program various meter factors or K factors to determine functionality of the adjustment feature. Use Appendix A, section 3.1 to determine the type of linearization applied and to verify that the adjustment complies with established regulations.

2.6.2 *Devices using step type linearization scheme*

2.6.2.1 In a step type adjustment scheme, a single correction factor is applied over each specific range of flow rates. For this simple and common approach, the correction factors (up to 5) and the corresponding range of flow rates are programmed to the device, as specified by the manufacturer. The calculated corrected meter factor (MF) or corrected K factor remains constant over the specified range of flow rates and only steps to a new value when the flow rate lies within a different range. NO

2.6.2.2 Determine the minimum and maximum input frequencies, and the maximum flow rate (Q_{max}) for the device under test. These values are required to establish test points across the full operating range of the linearization feature.

2.6.2.3 Confirm the number of meter factors allowed, as specified by the manufacturer (usually 4 or 5). Divide the maximum flowrate by the number of meter factors permitted and program the values below into the device. Take care to program the values in ascending order of flow rates, starting from the minimum value, unless otherwise specified by the manufacturer. NO

Note: Depending on the design of the device either the error factors, the meter factors or the K factors may be specified and programmed. Select the appropriate column from the tables below to program the device accordingly.

a) If 4 meter factors are permitted:

Test points	(% Q_{max}) (%)	Error factor (%)	Meter factor	K factor (Pulses/L)
1	25	0.05	0.99950	0.99950 x Base K
2	50	0.24	0.99760	0.99760 x Base K
3	75	0.00	1.00000	1.00000 x Base K
4	100	-0.24	1.00240	1.00240 x Base K

b) If 5 meter factors are permitted:

Test points	(% Q_{max}) (%)	Error factor (%)	Meter factor	K factor (Pulses/L)
1	20	0.05	0.99950	0.99950 x Base K
2	40	0.24	0.99760	0.99760 x Base K
3	60	0.00	1.00000	1.00000 x Base K

Document Title: LINEARIZATION FUNCTIONS INCORPORATED IN MEASURING INSTRUMENTS Document number: VO-AP-037	Version No.: 00.02	Page 9 of 19
---	---------------------------	---------------------

4	80	-0.24	1.00240	1.00240 x Base K
5	100	0.00	1.00000	1.00000 x Base K

<p>Document Title: LINEARIZATION FUNCTIONS INCORPORATED IN MEASURING INSTRUMENTS Document number: VO-AP-037</p>	<p>Version No.: 00.02</p>	<p>Page 10 of 19</p>
---	----------------------------------	-----------------------------

2.6.2.4 The minimum number of pulses required to achieve an error resolution of 0.01% is 10,000. All test runs performed must include at least this number of pulses.

2.6.2.5 Using the test sheet in Appendix B, perform test runs on the device at the recommended flow rates below, ensuring to input at least the minimum number of pulses at each different rate. Select frequencies that will result in flow rates that fall in between the set points for the meter factors entered in section 2.6.2.3. As a minimum, run tests as follows:

Run	Comments
1	Select a frequency that results in a flow rate below the first point programmed in 2.6.2.3
2	Select a frequency that results in a flow rate that lies between the first and second points programmed in 2.6.2.3
3	Select a frequency that results in a flow rate that lies between the second and third points programmed in 2.6.2.3
4	Select a frequency that results in a flow rate that lies between the third and fourth points programmed in 2.6.2.3 (if a minimum of 4 factors are used)
5	Select a frequency that results in a flow rate that lies between the fourth and fifth points programmed in 2.6.2.3 (if a minimum of 5 factors are used)
6	Select a frequency that results in a flow rate that lies above the last point programmed in 2.6.2.3

2.6.3 *Devices using linear interpolation linearization scheme*

2.6.3.1 In this scheme, referred to as “linear interpolation” (sometimes also referred to as “point-to-point linearization”), separate and discrete straight lines of the form $Y = mX + b$ are drawn between adjacent predetermined calibration values. The “Y” values (either corrected meter factors (MF) or corrected K factors) are calculated relative to the pulse frequency rate “X”. These values are used to correct the raw meter pulse signal and provide an estimate of the true value of flow.

2.6.3.2 Same as 2.6.2.2.

2.6.3.3 Same as 2.6.2.3.

2.6.3.4 Same as 2.6.2.4

2.6.3.5 Same as 2.6.2.5

Document Title: LINEARIZATION FUNCTIONS INCORPORATED IN MEASURING INSTRUMENTS	Version No.: 00.02	Page 11 of 19
Document number: VO-AP-037		

2.6.4 Devices using curve fitting of the form $Y = a + b(1/X) + cX + d(X^2) + e(X^3)$

2.6.4.1 The third method employs the reduction of calibration data, (meter factor or K factor “Y” vs flow rate “X”), using a preselected modelling equation. One model commonly chosen is a 4th order equation in the form of $Y = a + b(1/X) + c(X) + d(X^2) + e(X^3)$. The data manipulation is usually performed using software external to the flow computer or correction device, and results in a series of coefficients (a, b, c, d, e, etc.) and an estimate of the uncertainty of the curve fit. The equation coefficients are then programmed into the correction device or flow computer. The calculated corrections are then used by the flow computer or correction device to correct the “raw meter pulse signal” and provide an estimate of the true value of flow.

2.6.4.2 Assuming that the model is a 4th order equation, program the following coefficients into the correction device for evaluation purposes:

Coefficient	Value
a	6.5072493
b	-62.267514
c	-0.13650801
d	0.00085092719
e	-5.105311 x 10 ⁻⁷

2.6.4.3 Using the test sheet in Appendix B, perform test runs on the device at the recommended flow rates below, ensuring to input at least the minimum number of pulses at each different rate. Select frequencies that will result in flow rates that span the full range of the device’s capabilities.. As a minimum, run tests as follows:

Run	% Q _{max}	Comments
1	10	Select a frequency that results in a flow rate that lies between 0% and 20% of the maximum.
2	30	Select a frequency that results in a flow rate that lies between 20% and 40%. maximum.
3	50	Select a frequency that results in a flow rate that lies between 40% and 60% maximum.
4	70	Select a frequency that results in a flow rate that lies between 60% and 80% maximum.
5	90	Select a frequency that results in a flow rate that lies between 80% and 100% maximum.
6	110	Select a frequency that results in a flow rate that lies above 100% of the specified maximum.

<p>Document Title: LINEARIZATION FUNCTIONS INCORPORATED IN MEASURING INSTRUMENTS Document number: VO-AP-037</p>	<p>Version No.: 00.02</p>	<p>Page 12 of 19</p>
---	----------------------------------	-----------------------------

2.7 Calculations

2.7.1 Calculations of K factor or Meter Factor (MF) for a step type linearization method

2.7.1.1 To calculate the K factor or MF during test runs, record the flow rate. From the step graph of the K factor (Y) versus flow rate (X) programmed to the device, move along the X axis to the recorded flowrate. Read the corresponding K factor (Y value)

2.7.1.2 Sample calculation for step type-linearization method

Assume that a device can accept 4 K factors that are programmed as per the table presented in section 2.6.2.3(a). Then for any flow rates in between 25% Q_{max} and 50% Q_{max} the K factor is 0.99950 x Base K factor. Also for any flow rates above 100% Q_{max} the K factor is 1.00240 x Base K factor.

2.7.2 Calculations of K factor or Meter Factor (MF) for the linear interpolation linearization method

2.7.2.1 With this type of linearization scheme, the error factors are calculated by interpolating in between two set data points. To calculate the K factor or MF during test runs, record the flow rate. From the linear graph of the K factor (Y) versus flowrate (X) programmed to the device, move along the X axis to the recorded flow rate. Read the corresponding K factor (Y value), which can be calculated as follows:

$$Y = Y_1 + \frac{(X - X_1)}{(X_2 - X_1)} \times (Y_2 - Y_1)$$

where Y_2 = K factor of next highest set point
 X_2 = Flow rate of next highest set point
 Y_1 = K factor of next lowest set point
 X_1 = Flow rate of next lowest set point
 Y = K factor to be calculated
 X = Flow rate of current test

2.7.2.2 Sample calculation for linear interpolation type linearization method

Assume that a device can accept 5 MFs that are programmed as per the table presented in section 2.6.2.3(b). Then for a flow rate of 30% Q_{max} the MF is 0.99855, calculated as follows:

$$Y = 0.9995 + \frac{(30 - 20)}{(40 - 20)} \times (0.9976 - 0.9995) = 0.99855$$

Document Title: LINEARIZATION FUNCTIONS INCORPORATED IN MEASURING INSTRUMENTS	Version No.: 00.02	Page 13 of 19
Document number: VO-AP-037		

2.7.3 *Calculations of K factor or Meter Factor (MF) for the curve fitting linearization method*

2.7.3.1 With the curve fitting scheme, the error factors are calculated using coefficients for a polynomial specified by the manufacturer, usually of the form of $Y = a + b(1/X) + c(X) + d(X^2) + e(X^3)$. To calculate the K factor or MF during test runs, record the flow rate. From the polynomial graph of the K factor (Y) versus flow rate (X) programmed to the device, move along the X axis to the recorded flow rate. Read the corresponding K factor (Y value), which can also be calculated by substituting the flow rate (X value) into the specified curve.

2.7.3.2 Sample calculation for curve fitting type linearization method

If the coefficients in section 2.6.4.2 above are programmed into the device, then the expected theoretical values for the correction factor and the volume at the flow rates below are:

Test points	Flow rate (L/min)	Expected Meter factor	Expected K factor (Pulses/L)	Expected Volume (L)
1	20	1.00000	1.00000 x Base K	Pulse count ÷ (1.00000 x Base K)
2	50	0.50000	0.50000 x Base K	Pulse count ÷ (0.50000 x Base K)
3	90	0.05000	0.05000 x Base K	Pulse count ÷ (0.05000 x Base K)
4	130	1.54126	1.54126 x Base K	Pulse count ÷ (1.54126 x Base K)
5	180	6.18250	6.18250 x Base K	Pulse count ÷ (6.18250 x Base K)
6	110	13.64210	13.6421 x Base K	Pulse count ÷ (13.6421 x Base K)

Note: For other flowrates calculate the expected correction factor using the recommended coefficients in section 2.6.4.2.

2.7.4 *Linearization Error Calculations*

2.7.4.1 Regardless of the correction scheme used to determine a true volume, the linearization error is a function of the volume indicated by the device ($V_{indicated}$) and the expected theoretical volume ($V_{expected}$) calculated as follows.

$$\text{Linearization Error (\%)} = \frac{V_{indicated} - V_{expected}}{V_{expected}} \times 100$$

where

$$V_{expected} = \frac{\text{Pulse count}}{\text{Calculated Linearizing K factor}} \quad \text{if the K factor is programmed}$$

Document Title: LINEARIZATION FUNCTIONS INCORPORATED IN MEASURING INSTRUMENTS Document number: VO-AP-037	Version No.: 00.02	Page 14 of 19
--	---------------------------	----------------------

or

$$V_{\text{expected}} = \frac{\text{Pulse count} \times \text{Calculated Linearizing Mf}}{\text{Base K factor}} \quad \text{if Meter Factor is programmed}$$

2.8 Pass/Fail Criteria

Description	Criteria	Reference	Pass-Fail
General Requirements	Kindly refer to Appendix 3.1 "General Requirements Checklist - Linearization function".	SVM-1	
Linearization Error	Must not exceed $\pm 0.02\%$???	

Note: The Linearization spreadsheet ASL_Linearization.xls is available to help interpolate meter factors and calculate the percentage errors automatically. Kindly use the spreadsheet in conjunction with the test sheet presented in Appendix B to assist you in the evaluation.

Document Title: LINEARIZATION FUNCTIONS INCORPORATED IN MEASURING INSTRUMENTS Document number: VO-AP-037	Version No.: 00.02 Page 15 of 19
--	-------------------------------------

3.0 APPENDICES, WORK SHEETS AND TABLES

3.1 Appendix A: General Requirements Checklist - Linearization function

Comments	Comments	Comments
1) Linearization function characteristics: a) Type of function: G Step G Linear G Function Desc: _____ Decs: _____ - b) Number of programmable points: _____ Resolution: _____ c) Adjustment variable: G K factor or G Meter factor d) Sampling frequency: _____		
2) Is the means of adjustment used for processing pulses in order to vary measurement results sealable and located so as to be inaccessible without the removal of a portion of the exterior housing? SVM1-8	G N/A G NC G C	
3) If the means of adjustment is accessible without the removal of the exterior housing, then: a) Is the adjustment range less than $\pm 2\%$ of the volume of liquid delivered? SVM1-9(a) b) Is the adjustment range sealable? SVM1-9(b) c) Is the means of adjustment adjustable while the device is operating? SVM1-9(c)	G N/A G NC G C G N/A G NC G C G N/A G NC G C	

Date: _____ Project #: _____

Document Title: LINEARIZATION FUNCTIONS INCORPORATED IN MEASURING INSTRUMENTS Document number: VO-AP-037	Version No.: 00.02	Page 16 of 19
---	---------------------------	----------------------

Operator: _____ **Device:** _____

Document Title: LINEARIZATION FUNCTIONS INCORPORATED IN MEASURING INSTRUMENTS Document number: VO-AP-037	Version No.: 00.02	Page 17 of 19
---	--------------------	---------------

General Requirements Checklist - Linearization function (continued)

		Comments
4) If the means of adjustment automatically selects a predetermined correction factor that corresponds to the flow rate in order to linearize the meter accuracy curve, then:		
a) Is the adjustment range less than $\pm 0.25\%$ between adjacent factors? SVM1-10(a)	G N/A G NC G C	
b) Are the correction factors readily verifiable either by means of display or printing of the factors, or by other means? SVM1-10(b)	G N/A G NC G C	

Date: _____ **Project #:** _____

Document Title: LINEARIZATION FUNCTIONS INCORPORATED IN MEASURING INSTRUMENTS Document number: VO-AP-037	Version No.: 00.02	Page 18 of 19
--	--------------------	---------------

Operator: _____ **Device:** _____

Document Title: LINEARIZATION FUNCTIONS INCORPORATED IN MEASURING INSTRUMENTS Document number: VO-AP-037	Version No.: 00.02	Page 19 of 19
--	---------------------------	----------------------

3.2 Appendix B

Linearization function test sheet

	A	B	C	D	E	F	G
Run	Pulses	Frequency (Pulses/Sec)	Expected Flow rate [[60 * B] / D] (L/min)	Expected K Factor [Interpolated] (Pulses/L)	Expected Volume [A / D] (L)	Indicated Volume [Device] (L)	% Error [[F-E] / E] * 100] (%)
1							
2							
3							
4							
5							
6							
7							
8							
9							
10							
11							
12							
13							
14							
15							
16							
17							
18							
19							
20							

Date: _____

Project #: _____

Operator: _____

Device: _____